

Lecture Note
On
Automobile Engineering & Hybrid
Vehicle

6th Semester

By

Prof. Debasish Mohapatra



Department of Mechanical Engineering
Raajdhani Engineering College

INTRODUCTION

Define automobile.

Ans) Automobile is a self-propelled wheeled vehicle which is driven by internal combustion engine. It is used for transporting goods and passengers upon the ground.

State the needs of automobile.

Ans) Automobiles are required for transporting goods and passengers from one place to another. There are also some special purpose automobiles which are used in different fields of work such as - bulldozer, concrete mixture, army vehicles, fire vehicles, ambulance, dumper, mobile crane etc.

What are the different types of automobiles? Classify.

Ans) Automobiles are classified on the following basis.

1) Purpose:

- *Passenger vehicles* :: Car, jeep, station wagon, bus etc.
- *Goods vehicles* :: Truck, pick-up etc.
- *Special purpose vehicles* :: Ambulance, fire engine, concrete mixtures etc.

2) Load Capacity:

- *Light duty vehicles* :: Car, jeep, scooter, motor cycle etc.
- *Heavy duty vehicles* :: Bus, truck, tractor, coach, off road vehicles etc.

3) Number of Wheels:

- *Two wheeler* :: Motor cycles, scooters, mopeds etc.
- *Three wheeler* :: Auto rickshaws
- *Four wheelers* :: Car, jeep, bus, truck etc.
- *Six wheelers* :: Bus, trucks etc

4) Fuel Used:

- *Petrol vehicles* :: Car, jeep, motor cycle, scooter etc
- *Diesel vehicle* :: Car, truck, tractor, bus, bulldozer etc.
- *Electric vehicles* :: Battery operated vehicles, solar powered vehicles

5) Suspension System Used:

- *Conventional type* :: Leaf spring
- *Independent* :: Coil spring, torsion bar, pneumatic

6) Drive of The Vehicle:

- *Right hand drive vehicle*
- *Left hand drive vehicle*
- *Front wheel drive vehicle*
- *Rear wheel drive vehicle*
- *Single wheel drive vehicle*
- *Two wheel drive vehicle*
- *Four wheel drive vehicle*
- *Six wheel drive vehicle*

What are the major components of automobile? State their functions.

Ans) Functions of major components of automobile are:

1. ***Engine*** :: It is a power generator which provides power to drive the vehicle.
2. ***Chassis*** :: It consists of a frame which holds the engine and body. It carries all major components like transmission, steering and suspension, braking unit, wheels and suspension system.
3. ***Power train*** :: It consists of the clutch, gearbox, drive shaft, differential and rear axle. It carries the engine power to the rear wheels.
4. ***Clutch*** :: It is used to engage or disengage the power train and engine.
5. ***Transmission*** :: It is the gear box which can produce variation in torque by changing the gear ratio between engine shaft and drive shaft.
6. ***Propeller shaft*** :: It connects the gear box to differential unit for power transmission.
7. ***Differential*** :: It can split the power of propeller shaft to the rear axle. It can produce variation in speed of rear wheels when the vehicle takes a turn.
8. ***Axles*** :: Axles are the shafts on which wheels are mounted. These transmit power to the wheels.
9. ***Wheels*** :: Wheels take load of the vehicle and produce tractive force to move the vehicle.
10. ***Steering system*** :: It is used for changing the direction of vehicle i.e left or right.
11. ***Braking system*** :: It is used for slowing down or stopping a moving vehicle.
12. ***Suspension system*** :: It is used to absorb vibrations due to the up and down motion of wheels on the road.
13. ***Electrical system*** :: It provides energy to operate the starting motor and to give power to all the accessories.
14. ***Ignition system*** :: It is used for the combustion of fuel by high voltage spark.
15. ***Fuel system*** :: It is used to supply fuel to the carburetor or injection system.
16. ***Cooling system*** :: It is used to cool the engine and maintain engine optimum temperature.
17. ***Lubrication system*** :: It is used to lubricate different moving components of engine to minimize friction loss and also used as a coolant.

What is chassis? Draw the layout of an automobile chassis with major components.

Ans) Automobile chassis is consists of a frame supporting the vehicle and all the major units responsible for propelling and controlling the vehicle.

Layout of automobile chassis:

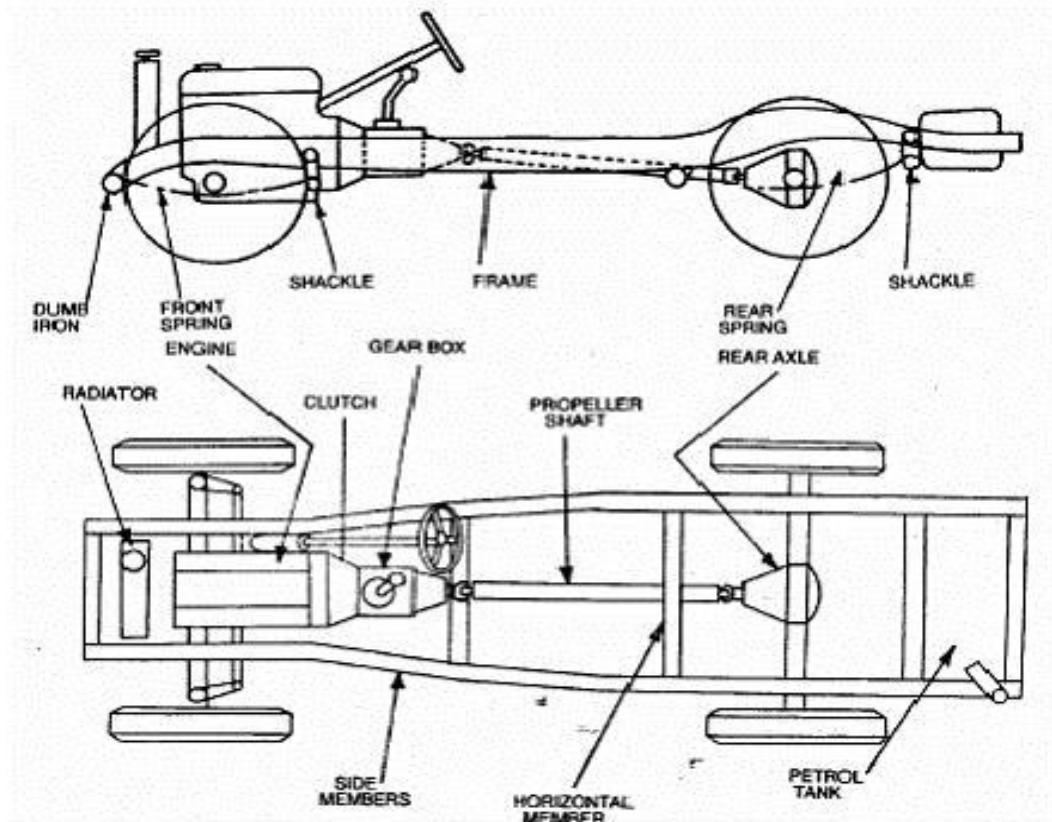

LAYOUT OF AUTOMOBILE CHASSIS

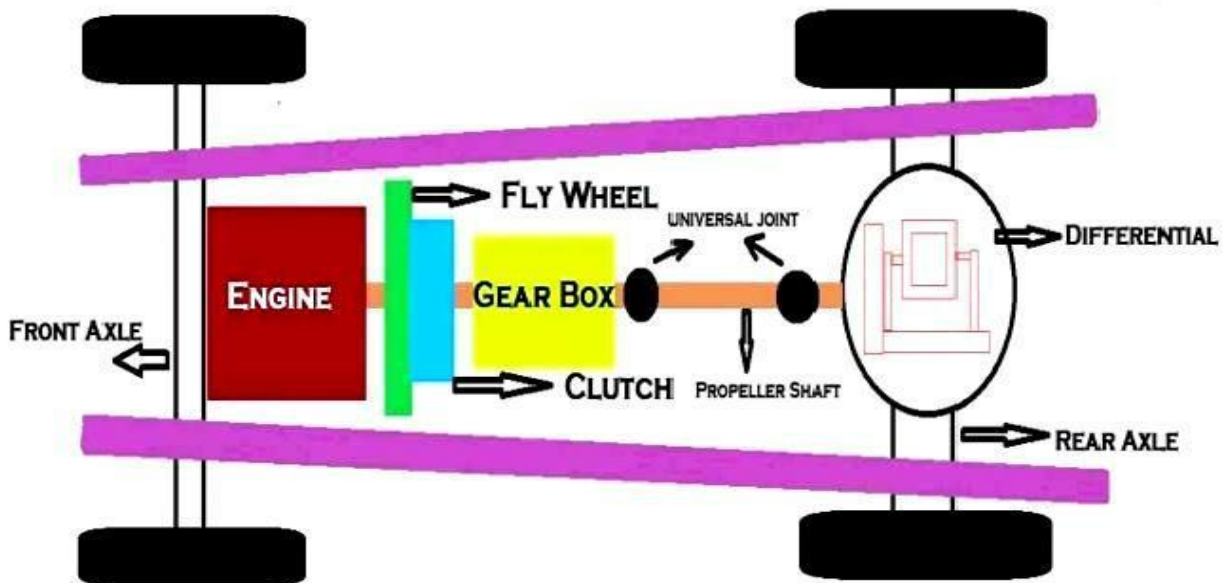

Draw the layout of bus chassis with major components and state the functions of main parts.

Ans) Layout of bus chassis:

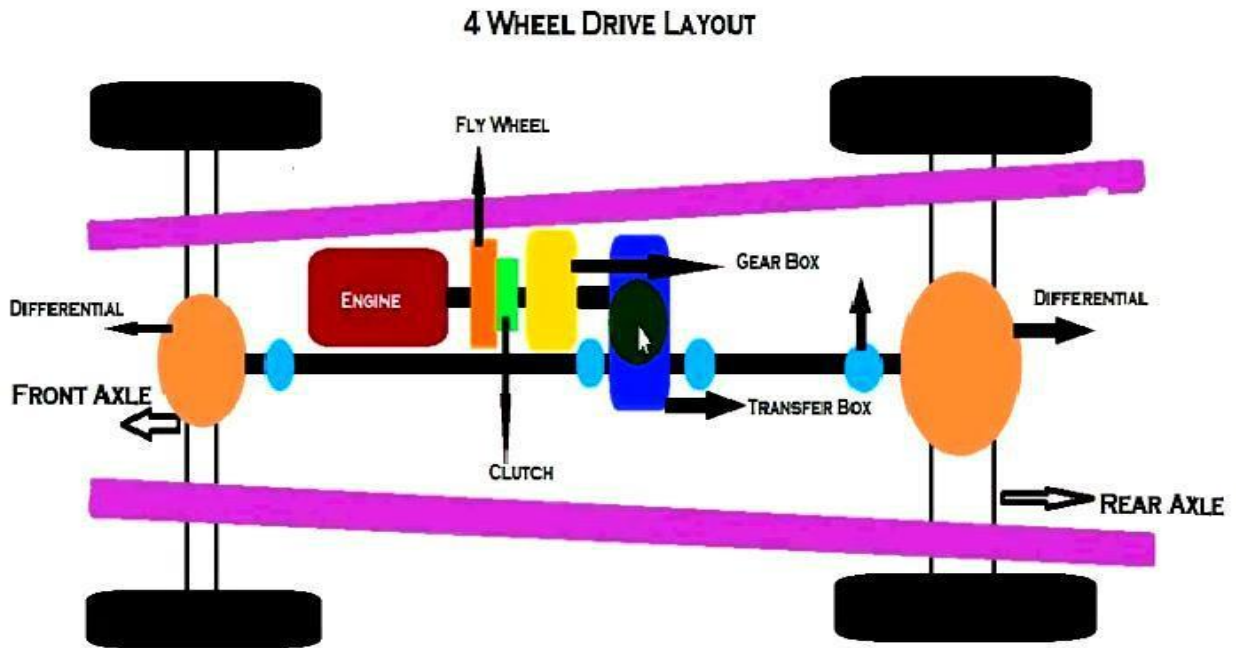

OR (Layout of chassis)

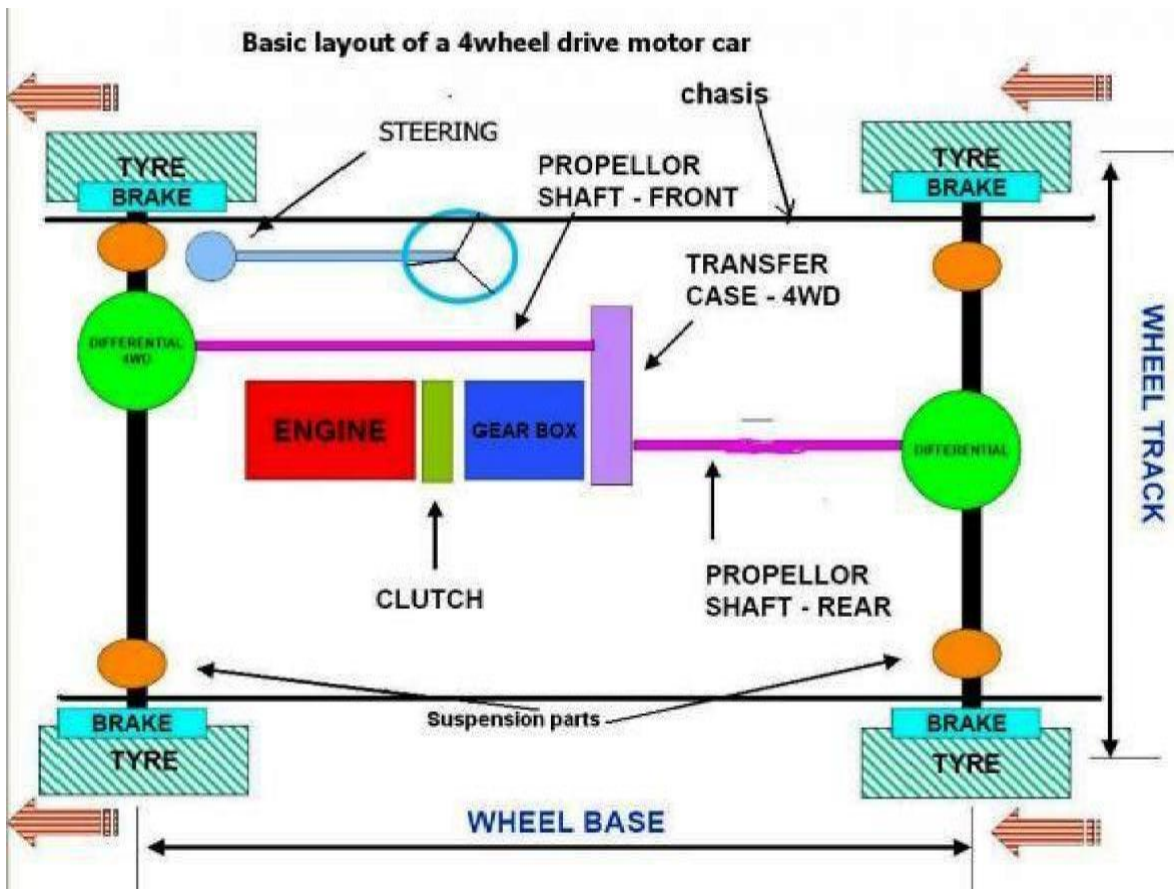

Write the manufacturer's specification of automobiles (scooter, motor cycle, bus & car).

Ans) Manufacturer's specification of automobiles:

❖ **Type:** Car, Truck, Scooter, Motor cycle, Bus etc.

❖ **Capacity:** 5 ton, 3 ton, 1 ton, 1/2 ton, 4 seater, 6 seater, 30 seater, 45 seater etc.

❖ **Make:** Tata Leyland, Standard etc.

❖ **Drive:** Left hand drive, Right hand drive, single wheel drive, two wheel drive, four wheel drive, six wheel drive.

❖ **Model:** Year of manufacture and code number

How automobile engines are classified? Explain.

Ans) Automobile I.C engines are classified on the following basis:

1) On the basis of fuel used:

- a. Petrol engine
- b. Diesel engine
- c. Gas engine

2) On the basis of number of strokes:

- a. Four stroke engines
- b. Two stroke engines

3) On the basis of thermodynamic cycle:

- a. Otto cycle engines
- b. Diesel cycle engines
- c. Dual cycle engines

4) Method of igniting the fuel:

- a. Spark ignition engine
- b. Compression ignition engine

5) Method of cooling:

- a. Water cooled engines
- b. Air cooled engines

6) Engine cylinders arrangement:

- a. Inline cylinder engines
- b. Opposite cylinder engines
- c. V-type engines
- d. Radial engines

TRANSMISSION SYSTEM

What are the functions of transmission system of automobile? What are its components?

Ans) The mechanism which transmits engine power to the wheels to drive the automobile is called as a transmission system.

Functions of transmission system:

- i) To disconnect the engine from driving wheels during starting and connect the engine with driving wheels during running.
- ii) To reduce the speed of the engine.
- iii) To turn the drive through 90^0 .
- iv) To provide relative movement between the engine and driving wheel

Components of transmission system:

- i) Clutch, ii) Gear box, iii) Propeller shaft, iv) Universal joint, v) Rear axle and differential, vi) driving wheels and tyres

What is clutch? Give a classification of clutch?

Ans) It is a device used in a transmission system of an automobile to engage and disengage the engine shaft to the transmission system. It is located between the engine and the gear box.

- When the clutch is engaged, the power transmits from the engine to the driven shaft and the vehicle moves.
- When the clutch is disengaged, the power does not transmit to the driven wheels and vehicle stops or slows down.

Classification of Clutch:

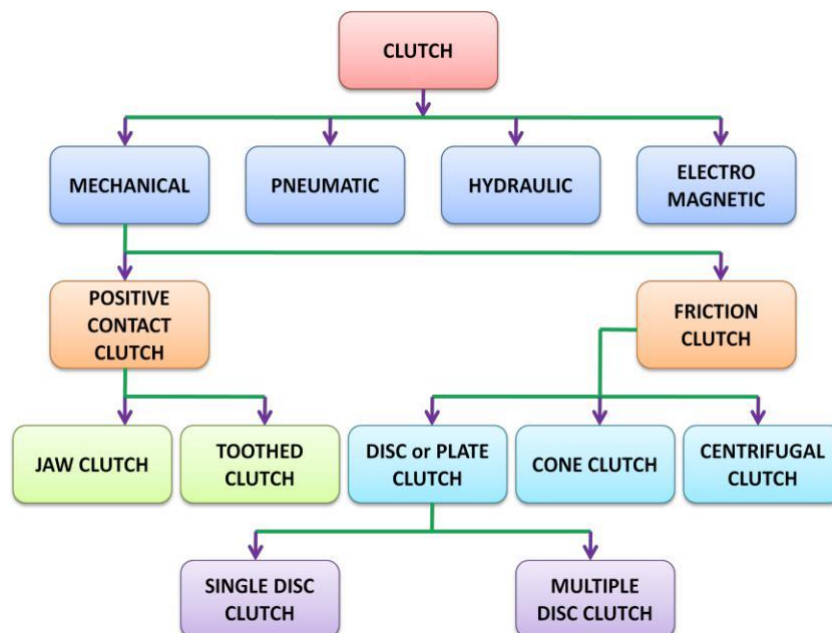

State the principle of operation of clutch?

Ans) Principle of operation of clutch:

The clutch principle is based on friction. When two friction surfaces are brought in contact with each other and pressed they are united due to friction between them. If one is revolved the other will also revolve.

What is the function of clutch?

Ans) Functions of clutch:

- ❖ To permit engagement or disengagement of the gear shaft to the engine shaft.
- ❖ To transmit the engine power to the road wheels smoothly without shock to the transmission system.
- ❖ To allow gear change without damage.

Explain the construction and working of single plate clutch with sketch.

Ans) Construction of Single plate clutch:

A single plate clutch consists of the following parts.

- A flywheel is rigidly fixed on the crankshaft of the engine.
- One clutch plate is mounted on the splined hub of the clutch shaft.
- Clutch plate is located between the flywheel and pressure plate.
- Clutch plate has friction linings on both sides to provide friction surfaces for power transmission.
- Coil springs are provided circumferentially on the pressure plate to provide axial force.
- A pressure plate is free to slide on the clutch shaft with the movement of clutch pedal.

A Single plate clutch is shown in figure.

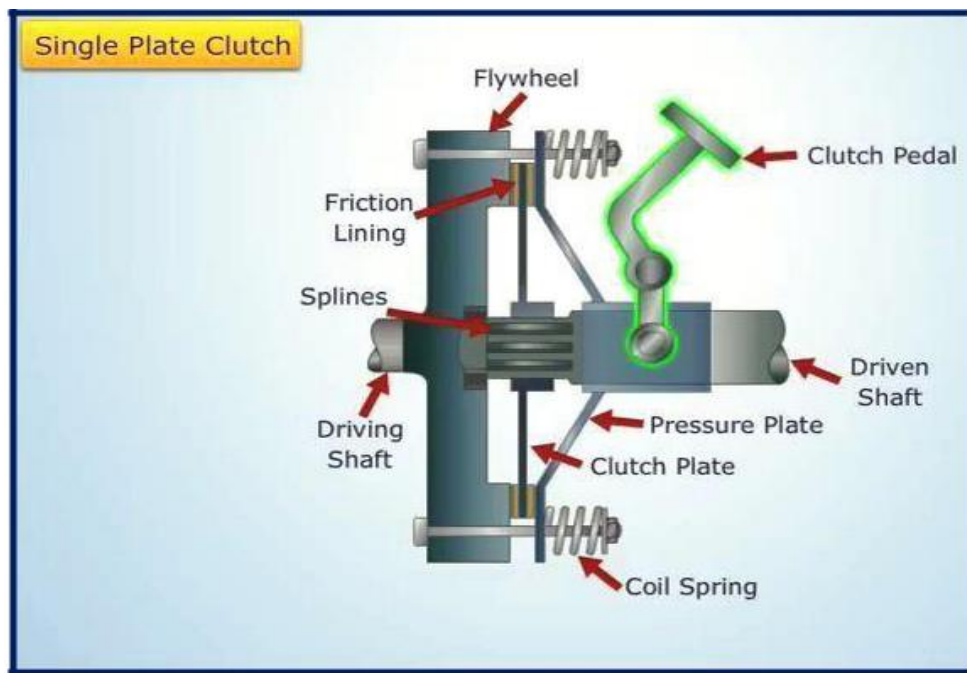

Working of Single plate clutch:

- When clutch is in engaged position, the clutch plate remains gripped between flywheel and pressure plate by friction linings. Due to friction on both sides, the clutch plate revolves with engine flywheel. Therefore, clutch transmits engine power to clutch shaft. Clutch shaft is connected to transmission (or gear box) of automobile. Thus, clutch transmits power from engine to transmission system.
- When the clutch pedal is pressed, clutch plate is disengaged. Because of this pressure plate moves back and clutch plate is disengaged from flywheel. Thus, clutch shaft stops rotating even if engine flywheel is rotating. In this position, power does not reach the wheels and vehicle also stops running.

Explain the construction and working of multiple plate clutch with sketch.

Ans) Construction of Multiple plate clutch:

Multi-plate clutch consists of the following parts.

- More than one clutch plates which are alternatively fitted with engine shaft and the shaft of gear box.
- More number of friction plates is fitted with the flywheel to provide large torque.
- Clutch plates are firmly held by the force of coil springs and they assembled in a drum.
- One plate slides in the grooves on the flywheel and the next plate slides on spines provided on pressure plate.

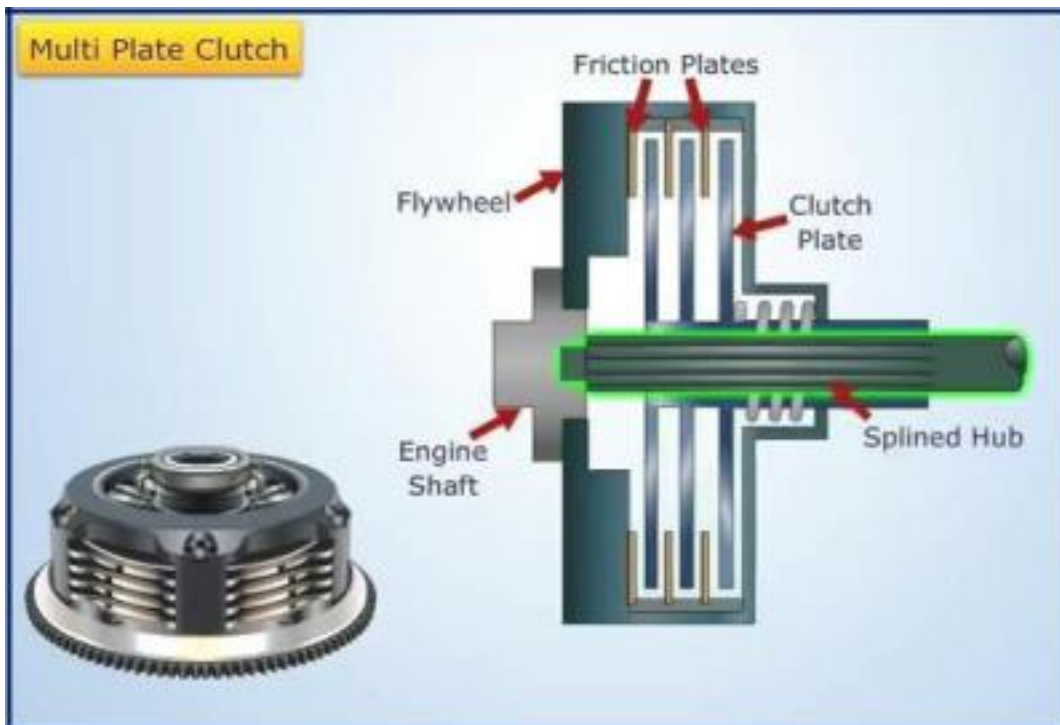

Working of Multiple plate clutch:

- When the clutch pedal is pressed, the pressure plate moves back against the force of coil spring, hence the clutch plates are disengaged and engine flywheel and gear box are decoupled.
- When clutch pedal is not pressed the clutch remain in engaged position and the power can be transmitted from engine flywheel to the gear box.

What is the need of gear box in automobile? Give a classification of gearbox.

Ans) Need of gear box (function):

- 1) It helps the engine to disconnect from the driving wheels with the help of clutch during the starting or running of the automobile.
- 2) It can provide large torque during starting and low torque during running of vehicle.
- 3) It can provide neutral position
- 4) It can move a vehicle in reverse direction.
- 5) It can provide smooth running of vehicle at different speeds.

Classification of gear box:

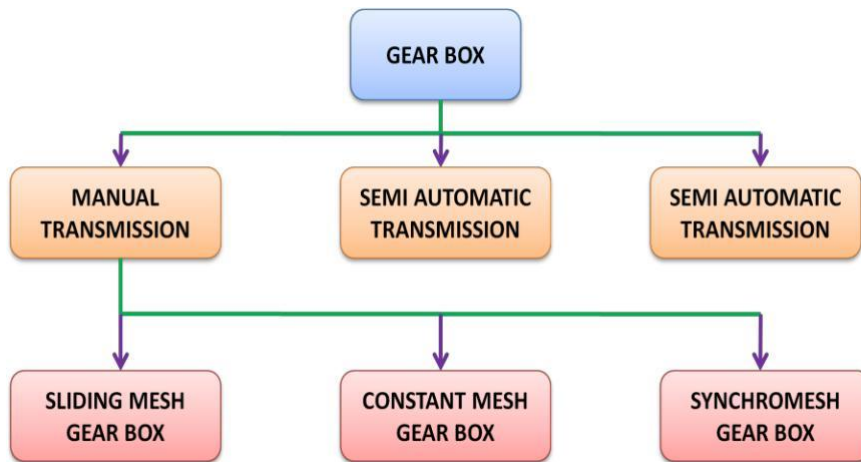

Q.9) With the help of neat sketch explain the construction and working of sliding mesh gear box.

Ans) Construction of Sliding mesh gear box:

A typical sliding mesh gear box is shown in figure. It consists of main shaft, clutch shaft and a counter shaft. Clutch shaft has one gear which is rigidly fixed to the clutch shaft. Main shaft has two gears which can slide horizontally. Counter shaft has four gears which can't slide.

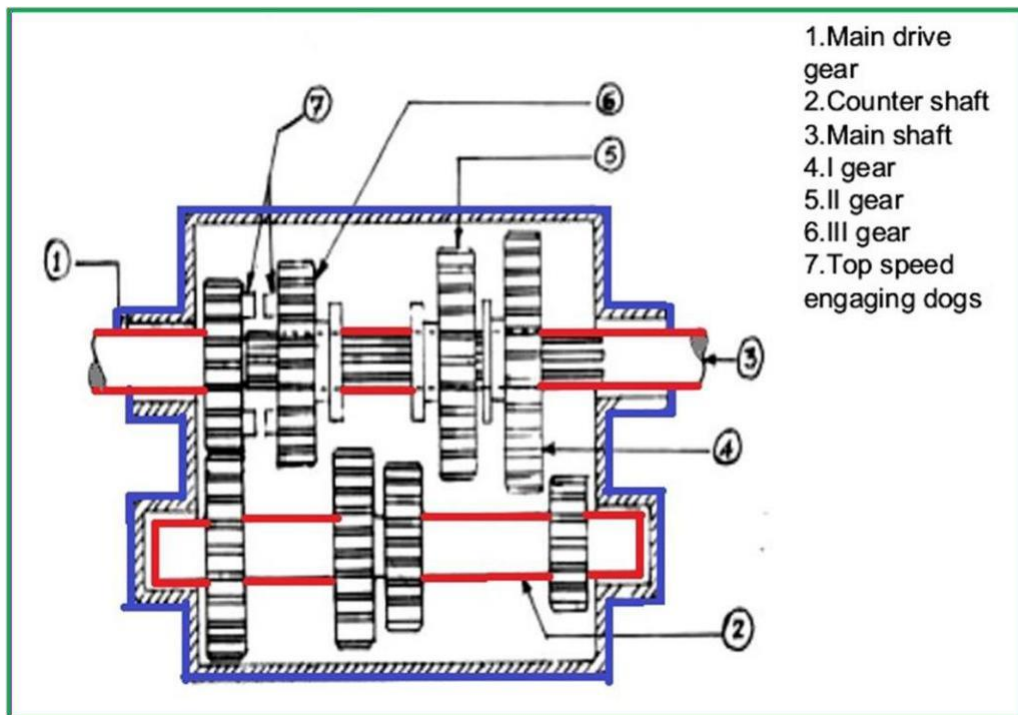

Working of Sliding mesh gear box:

❖ Neutral position:

In this position, the engine is in running condition, clutch remains engaged and clutch gear drives the counter shaft drive gear. The direction of rotation of countershaft is opposite to that of clutch shaft. In this position 1st, 2nd, 3rd and reverse gears are free. Thus, main (transmission) shaft does not rotate and automobile wheels do not rotate. So vehicle remains stationary.

- ❖ **First gear:**
In this position the first gear (large gear) on the main shaft slides and is connected to first gear on the countershaft. The direction of rotation of main shaft is same as that of clutch shaft. Small gear of countershaft meshes with larger gear on main shaft and produces speed reduction in the ratio 3:1.
- ❖ **Second gear:**
In this position the second gear on countershaft meshes with second gear (small gear on main shaft) on the main shaft. The direction of main shaft is same as that of clutch shaft. Speed reduction of the order of 2:1 is obtained in second gear.
- ❖ **Third gear:**
In this position the main shaft slides axially towards the clutch shaft so that main shaft is directly connected to the clutch shaft. The main shaft rotates at the same speed of clutch shaft. Thus, a speed ratio of 1:1 is obtained.
- ❖ **Reverse gear:**
When the shift lever is operated to engage the reverse gear, the larger (reverse) gear of the main shaft meshes with the reverse idler gear. Reverse idler gear is always connected to reverse gear on countershaft and changes the direction of rotation of main shaft. Thus, the direction of main shaft becomes opposite to that of clutch shaft. Therefore, wheels of the automobile start moving in backward direction.

Differentiate between sliding mesh and synchromesh gear box.

Ans) Sliding mesh : This is where the gears are not in constant mesh with each other and the gears on the main shaft slide over to mesh with the gears on the lay shaft/counter shaft.

Synchromesh : Synchromesh which uses Baulk rings to lock onto the gear first before the sliding sleeve comes over to lock on.

Explain the concept of automatic gear changing mechanism.

Ans) Automatic transmission system is the most advanced system in which drives mechanical efforts are reduced and different speeds are obtained automatically. It contains epicyclic gear arrangement, fluid coupling and torque converter. In this planetary gear sets are placed in series to provide transmission. Epicyclic gear system consisting of one or more outer gears, or planet gears, revolving about a central gear .By using epicyclic gear, different torque speed ratio can be obtained. It also compact the size of gear box.

Stages of automatic transmission :

- ❖ **Park(P)** : selecting the park mode will lock the transmission, thus restricting the vehicle from moving.
- ❖ **Reverse(R)** : selecting the reverse mode puts the car into reverse gear, allowing the vehicle to move backward.
- ❖ **Neutral (N)** : selecting neutral mode disconnects the transmission from the wheel.
- ❖ **Low (L):** selecting the low mode will allow you to lower the speed to move on hilly and middy areas.
- ❖ **Drive (D):** selecting drive mode allows the vehicle to move and accelerate through a range of gears.

What is the function of universal joint? Where it is used? Sketch a simple universal joint and mention its various parts.

Ans) Universal Joint:

Universal joint is used to connect two non parallel shafts inclined at some angle for transmitting torque between them.

In the transmission shaft of an automobile, two universal joints are used – one between main transmission shaft and propeller shaft and another between other end of propeller shaft and the differential.

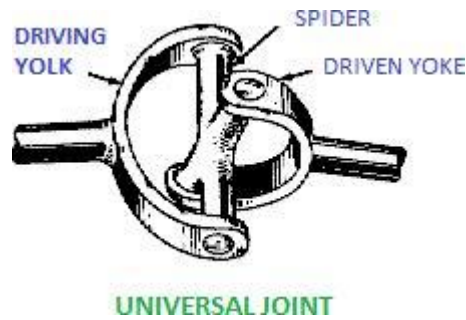

Explain the function of a slip joint.

Ans) A slip joint is provided between universal joint and propeller shaft to adjust for any change in length. When its spring is compressed propeller shaft shortens and when its spring is expanded, propeller shaft returns to original length.

What is the function of propeller shaft in the transmission system? Where it is used?

Ans) The propeller shaft is used to transmit power from transmission (gear box) to the differential. Propeller shaft transmits the rotary motion of main transmission shaft (coming from gear box) to the differential so that rear wheels can be rotated.

Propeller shaft is connected to main transmission shaft by universal joint and it is connected to differential pinion shaft by another universal joint.

Explain the construction of propeller shaft with a neat sketch.

Ans) Propeller shaft is made of a steel tube which can withstand torsional stresses and vibrations at high speeds. Its constructional details are shown in figure.

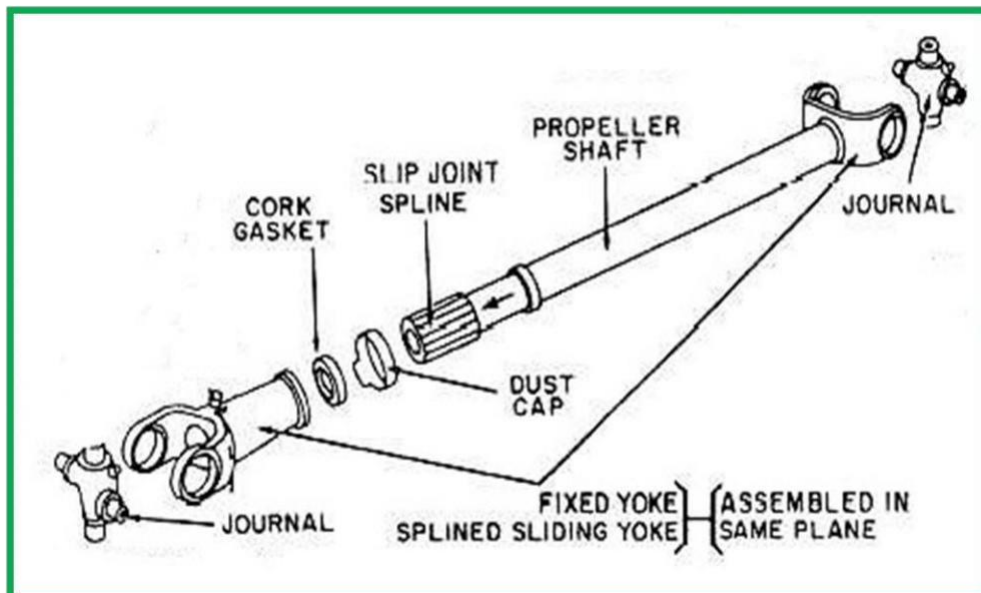

What do you mean by final drive? What is its function?

Ans) The final drive is composed of a bevel gear (or pinion) and crown wheel. The bevel pinion is connected to propeller shaft. The pinion is in mesh with the crown wheel of differential.

Final drive is the last stage of power transmission from propeller shaft to rear axles and then to wheels. It turns the propeller shaft motion at right angle to drive the rear axle.

What is the necessity of differential in an automobile? Explain the construction and working of differential.

Ans) Necessity of differential:

The differential is used to permit the relative movement between inner and outer wheels when vehicle takes a turn. The torque transmitted to each rear wheel is equal in this case, although their speed is different.

Construction of differential:

The construction of a simple differential is shown in Figure.

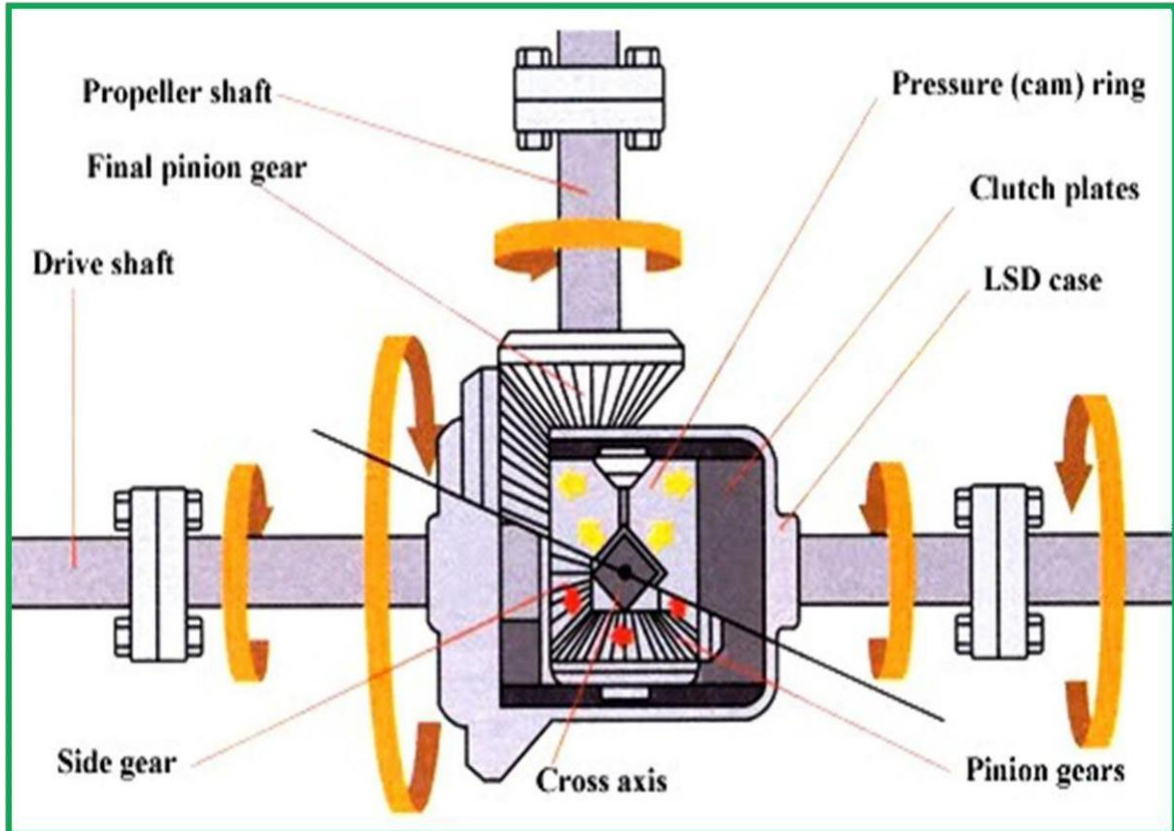

- It consists of sun gears, planet pinion, a cage, a crown wheel and a bevel pinion.
- A sun gear is attached to inner end of each rear axle (half shaft).
- A cage is attached on left axle.
- A crown gear is attached to the cage and the cage rotates with the crown gear.
- The crown gear is rotated by the bevel pinion.
- Crown gear and cage remain free on the left rear axle.
- Two planet pinions are on a shaft which is supported by the cage.
- The planet pinions mesh with the sun gears.
- The rear wheels are attached to outer ends of two rear axles.

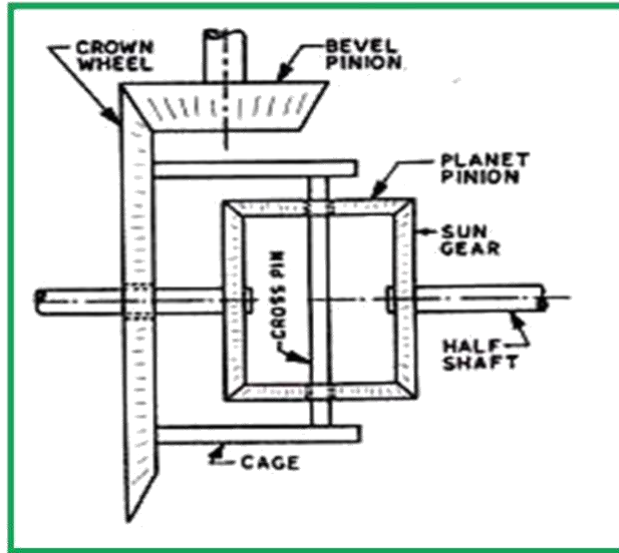

Working of differential:

When the cage rotates, sun gears rotate. Thus, the wheels also rotate. In case one inner wheel runs slower than other when the vehicle takes a turn, the planet gears spin on their shaft, transmit more rotary motion to outer wheel. When vehicle runs in straight line, the crown gear, cage, planet pinions and sun gears turn together as a unit. Thus there is no relative motion.

BRAKING SYSTEM

Define brake. State the need of braking system in automobile.

Ans) Brake is a mechanical device which inhibits motion. Brakes are applied on the wheels to stop or to slow down the vehicle.

Need of braking system:

- To slow down or stop the vehicle in the shortest possible time at the time of need.
- To control the speed of vehicle at turns and also at the time of driving on a slope.

State the principle of braking.

Ans) Brakes work on the following principle to stop the vehicle:

“The kinetic energy due to motion of the vehicle is dissipated in the form of heat energy due to friction between moving parts (wheel or wheel drum) and stationary parts of vehicle (brake shoes)”.

Give a classification of brakes.

Ans) Brakes are classified on the following basis:

Classification of Brakes:

1) On the basis of Mode of operation:

- a. Mechanical brakes (drum and disk brakes)
- b. Hydraulic brakes
- c. Air brakes
- d. Air hydraulic brakes
- e. Vacuum brakes
- f. Electric brakes

2) On the basis of method of actuation:

- a. Foot brake
- b. Hand brake

3) On the basis of action on front or rear wheels:

- a. Front wheel brakes
- b. Rear wheel brakes

4) On the basis of method of application of braking contact:

- a. Internally expanding brakes
- b. Externally contracting brakes

Describe various types of braking system used in automobile vehicle with diagram.

Ans) The various types of braking systems are as follows:

Air Brakes:

Air brakes are applied by the pressure of compressed air. Air pressure applies force on brake shoes through suitable linkages to operate brakes. An air compressor is used to compress air. This compressor is run by engine power.

Vacuum Brakes:

Vacuum brakes are a piston or a diaphragm operating in a cylinder. For application of brakes one side of piston is subjected to atmospheric pressure while the other is applied vacuum by exhausting air from this side. A force acts on the piston due to difference of pressure. This force is used to operate brake through suitable linkages.

Electric Brakes:

In electrical brakes an electromagnet is used to actuate a cam to expand the brake shoes. The electromagnet is energized by the current flowing from the battery. When flow of current is stopped the cam and brake shoes return to their original position and brakes are disengaged. Electric brakes are not used in automobiles as service brakes.

Hydraulic brakes:

The brakes which are actuated by the hydraulic pressure (pressure of a fluid) are called hydraulic brakes. Hydraulic brakes are commonly used in the automobiles. Hydraulic brakes work on the principle of Pascal's law.

Explain the construction and working of mechanical brake system.

Ans) DRUM OR SHOE BRAKE:

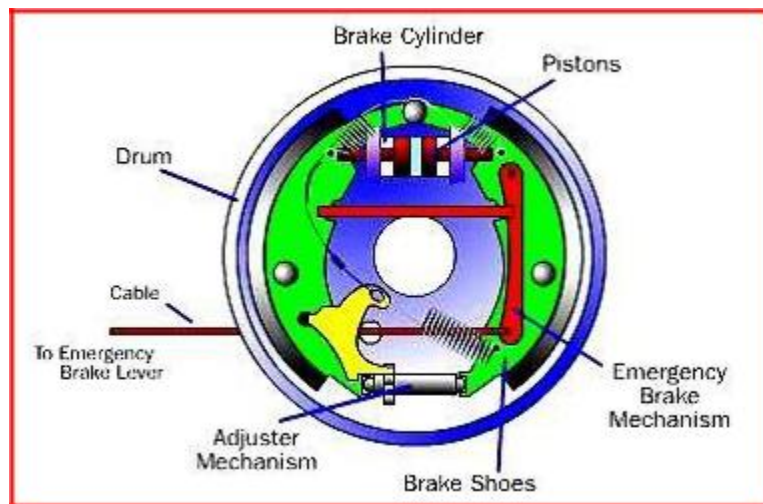

The drum brake has a metal brake drum that encloses the brake assembly at each wheel. Two curved brake shoes expand outward to slow or stop the drum which rotates with the wheel.

DISC BRAKES:

In a disc brake, the fluid from the master cylinder is forced into a caliper where it presses against a piston. The piston in turn squeezes two brake pads against the disc (rotor), which is attached to wheel, forcing it to slow down or stop.

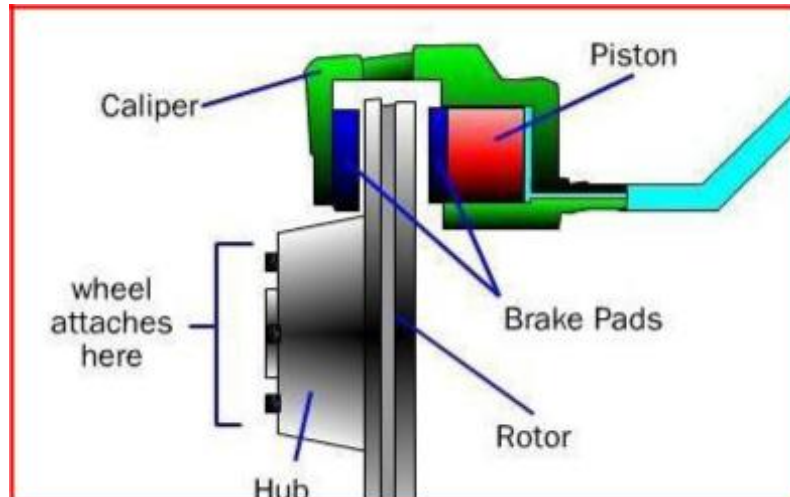

State the advantages and disadvantages of disc brakes.

Ans) *Advantage of Disc Brakes:*

- ❖ Resistance to wear as the discs remains cool even after repeated brake applications.
- ❖ Brake pads are easily replaceable.
- ❖ The condition of brake pads can be checked without much opening of brake system.

Disadvantage of Disc Brakes:

- ❖ More force is needed be applied as the brakes are not self emerging.
- ❖ Pad wear is more.
- ❖ Hand brakes are not effective if disc brakes are used in rear wheels also.

Briefly describe the construction and working of hydraulic brakes.

Ans) The brakes which are actuated by the hydraulic pressure (pressure of a fluid) are called hydraulic brakes. Hydraulic brakes are commonly used in the automobiles.

Principle:

Hydraulic brakes work on the principle of Pascal's law which states that, "pressure at a point in a fluid is equal in all directions in space". According to this law when pressure is applied on a fluid it travels equally in all directions so that uniform braking action is applied on all four wheels.

Construction of Hydraulic Brakes:

Figure shows the system of hydraulic brake of a four wheeler automobile. It consists of a master cylinder, four wheel cylinders and pipes carrying a brake fluid from master cylinder to wheel cylinder.

The master cylinder is connected to all the four-wheel cylinders by tubing or piping. All cylinders and tubes are fitted with a fluid which acts as a link to transmit pedal force from master cylinder to wheel cylinders.

Master cylinder consists of a piston which is connected to pedal through connecting rod. The wheel cylinder consists of two pistons between which fluid is filled.

Each wheel brake consists of a cylinder brake drum. This drum is mounted on the inner side of wheel. The drum revolves with the wheel. Two brake shoes which are mounted inside the drum remain stationary. Heat and wear resistant brake linings are fitted on the surface of the brake shoes.

The fluid filled in the hydraulic brake system is known as brake fluid. It is a mixture of glycerine and alcohol or castor oil and some additives.

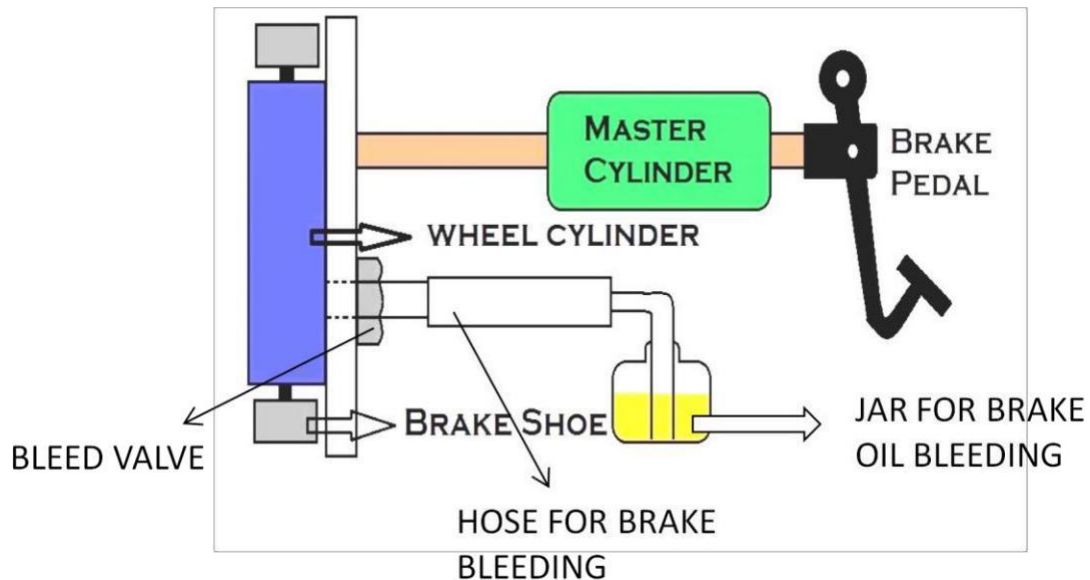

Application of Brakes

When brake pedal is pressed to apply the brakes, the piston in the master cylinder forces the brake fluid. This increases the pressure of fluid. This pressure is transmitted in all the pipes and up to all wheel cylinders according to Pascal's law. This increased pressure forces out the two pistons in the wheel cylinders. These pistons are connected to brake shoes. So, the brake shoes expand out against brake drums. Due to friction between brake linings and drum, wheels slow down and brakes are applied.

Release of Brakes

When pedal is released, the piston of master cylinder returns to its original position due to retractor spring provided in master cylinder. Thus, fluid pressure drops to original value. The retractor spring provided in the wheel cylinders pulls the brake shoes and contact between drum and brake linings is broken. Therefore, brakes are released.

What are the advantages and disadvantages of hydraulic brakes?

Ans) Advantages:

- ❖ Equal braking action on all wheels.
- ❖ Increased braking force.
- ❖ Simple in construction.
- ❖ Low wear rate of brake linings.
- ❖ Flexibility of brake linings.
- ❖ Increased mechanical advantage.

Disadvantages:

- ❖ Whole braking system fails due to leakage of fluid from brake linings.
- ❖ Presence of air inside the tubing ruins the whole system.

What is the use of master cylinder? Describe the function of a master cylinder with neat sketch.

Ans) Master cylinder consists of a piston which is connected to pedal through connecting rod. It produces hydraulic force by pressing the brake fluid which exerts force on the brake.

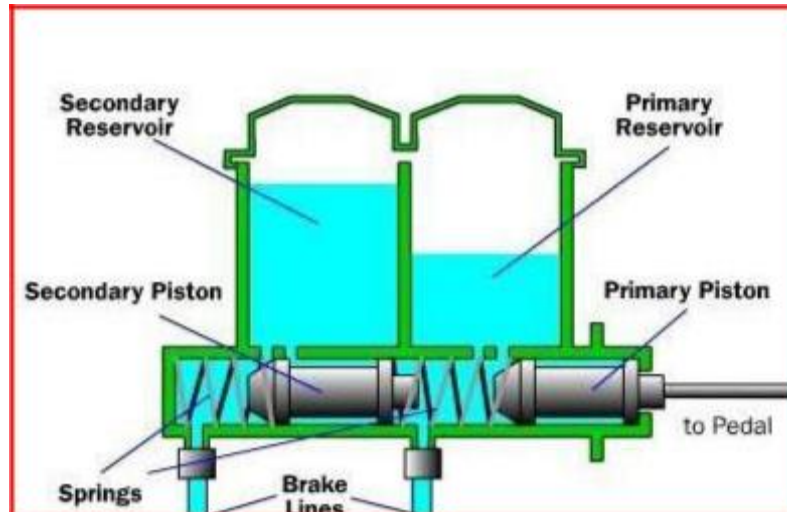

When we press the brake pedal, it pushes on primary piston of master cylinder through a linkage. Pressure is built in the cylinder and the lines as the brake pedal is depressed further. The pressure between the primary and secondary piston forces the secondary piston to compress the fluid in its circuit. If the brakes are operating properly, the pressure will be same in both the circuits. If there is a leak in one of the circuits, that circuit will not be able to maintain pressure.

What is parking brake or emergency brake?

Ans) Parking brakes or emergency brakes are essentially mechanical brakes operated by hand. These are used to prevent the motion of vehicle when parked at a place or when parked on slopes. In cars, these brakes are generally attached to rear wheels. In this type, a cable connects the hand lever to the brake. Brakes are applied by pulling the lever and released by pushing a button (provided on lever) and pressing the lever down.

Why bleeding of brakes is required?

Ans) When air enters, into the brake system and any brake line is disconnected, bleeding of brakes has to be done. Since air is compressible so any presence of air inside brake lining does not allow to transmit brake force to apply brakes. Therefore, the system must be free from presence of air. *Bleeding is the process of removal of air from the braking system.*

COOLING & LUBRICATION

What is the function of engine cooling system?

Ans) The cooling system has four primary functions. These functions are as follows:

- ❖ Removes excess heat from the engine
- ❖ Maintains a constant engine operating temperature
- ❖ Increases the temperature of a cold engine quickly
- ❖ Provides heater operation to warm the passenger compartment

What are the types of cooling system and explain the water cooling system in detail.

OR Describe the pump circulating water cooling system with neat sketch.

Ans) The different Types of cooling system are:

- ❖ Air cooling system
- ❖ Liquid cooling system
- ❖ Forced circulation system
- ❖ Pressure cooling system

Water cooling system/Liquid cooling system:

A simple liquid-cooled system consists of a radiator, coolant pump, piping, fan, thermostat, and a system of water jackets and passages in the cylinder head and block through which the coolant circulates.

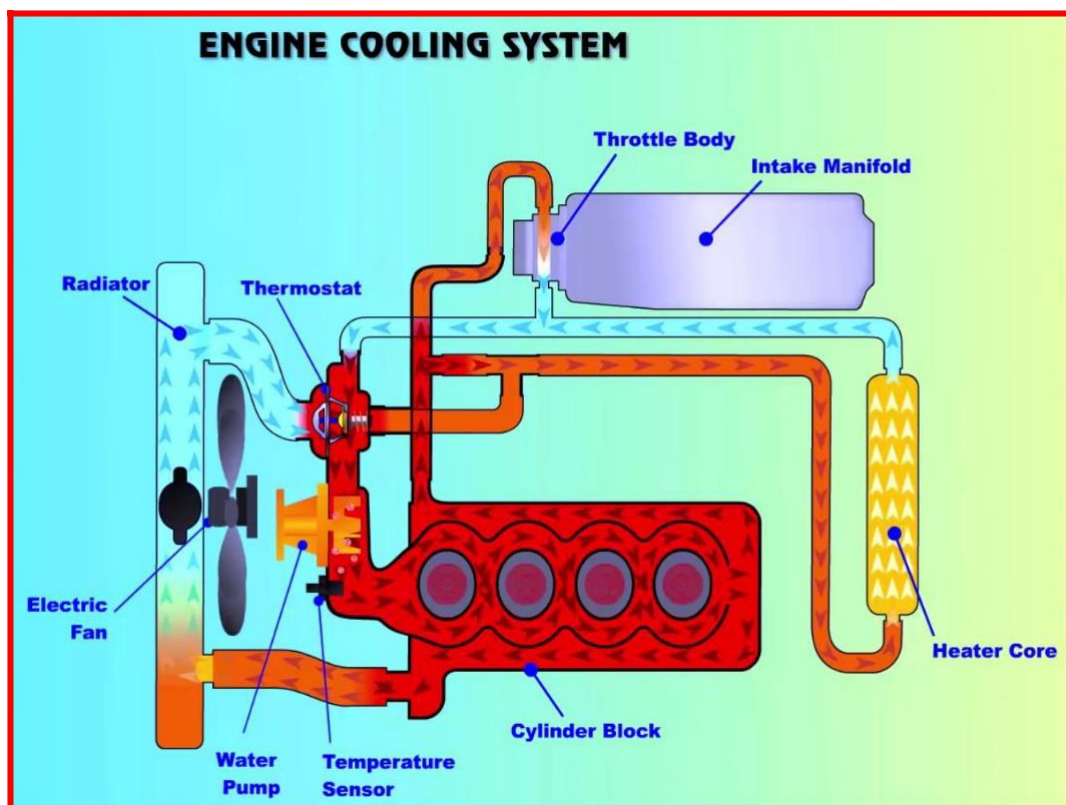

The pump draws the coolant/water from the bottom of the radiator, forcing it through the water jackets and passages, and ejects it into the upper radiator tank. The coolant then passes through a set of tubes to the bottom of the radiator from which the cooling cycle begins.

The radiator is situated in front of a fan that is driven either by the water pump or an electric motor. The fan ensures airflow through the radiator at times when there is no vehicle motion. The heating in the engine and the cooling in the radiator therefore create a natural circulation that aids the water pump.

Describe the components used in engine cooling system in Car.

Ans) The main components of cooling system are:

- ❖ Water pump
- ❖ Radiator
- ❖ Thermostat
- ❖ Coolant temperature sensor
- ❖ Coolant
- ❖ Fan
- ❖ Water jacket

Water pump pumps the coolant in cooling system. Radiator is a heat exchanger used to transfer the excess heat developed by the engine to the atmosphere. Thermostat is a valve which regulates the flow of coolant and helps to maintain the proper operating temperature for the engine. Coolant temperature sensor is used to monitor the engine temperature. The engine is having a passage for the flow of coolant known as water jacket.

Explain about the air cooling system in IC engines.

Ans) Air cooled system is generally used in small engines ranging up to 15-20 kW and in aero plane engines. In this system fins or extended surfaces are provided on the cylinder walls, cylinder head, etc. Heat generated due to combustion in the engine cylinder will be conducted to the fins and when the air flows over the fins, heat will be dissipated to air.

The amount of heat dissipated to air depends upon:

- (a) Amount of air flowing through the fins.
- (b) Fin surface area.
- (c) Thermal conductivity of metal used for fins.

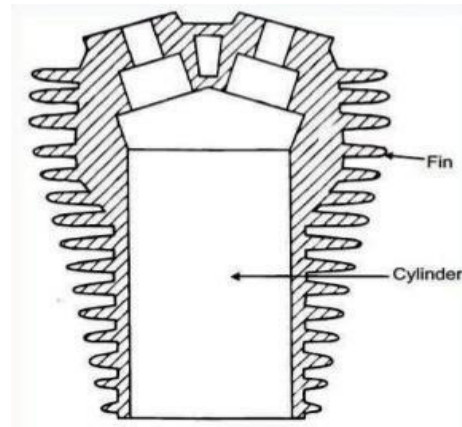

What are the advantages and disadvantages of air cooling system?

Ans) Advantages of Air Cooled System

Following are the advantages of air cooled system:

- ❖ Radiator/pump is absent hence the system is light.
- ❖ In case of water cooling system there are leakages, but in this case there are no leakages.
- ❖ Coolant and antifreeze solutions are not required.
- ❖ This system can be used in cold climates, where if water is used it may freeze.

Disadvantages of Air Cooled System

- ❖ Comparatively it is less efficient.
- ❖ It is used in aero planes and motorcycle engines where the engines are exposed to air directly.

What are the advantages and disadvantages of air cooling system?

Ans) Advantages Water Cooling System:

- ❖ Uniform cooling of cylinder, cylinder head and valves.
- ❖ Specific fuel consumption of engine improves by using water cooling system.
- ❖ If we employ water cooling system, then engine need not be provided at the front end of moving vehicle.
- ❖ Engine is less noisy as compared with air cooled engines, as it has water for damping noise.

Disadvantages of Water cooling system:

- ❖ It depends upon the supply of water.
- ❖ The water pump which circulates water absorbs considerable power.
- ❖ If the water cooling system fails then it will result in severe damage of engine.
- ❖ The water cooling system is costlier as it has more number of parts. Also it requires more maintenance and care for its parts.

What are the functions of lubrication system?

Ans) The functions of an engine lubrication system are as follows:

- ❖ Reduces the friction and wear between moving parts
- ❖ Helps transfer heat and cool engine parts
- ❖ Cleans the inside of the engine by removing contaminants
- ❖ Absorbs shocks between moving parts to quiet engine operation and increase engine life

Describe the components of lubrication system of I.C engine. Explain how lubricating system works.

Ans) The main components of lubricating system are:

- ❖ Sump for lubricant and oil strainer
- ❖ Oil pump
- ❖ Pressure regulator
- ❖ Oil filter

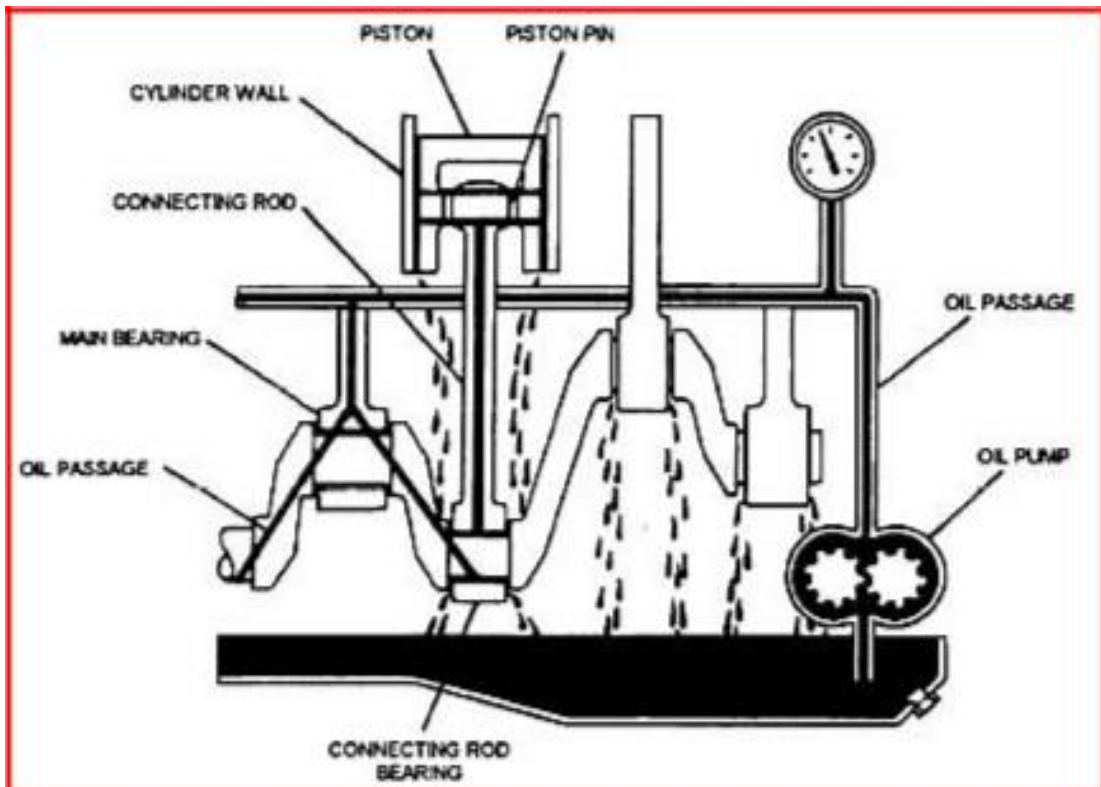

Working:

The Oil pump is operated by the engine, which sucks oil from the sump through oil strainer. Oil pump discharges the oil to Oil filter at high pressure. The oil pressure regulator checks the required oil pressure and supplies clean oil by removing dust from it. The pressurized oil flows through the oil lines and galleries to lubricate the moving engine parts. The galleries lubricate all engine parts and then the oil return back to the sump for recycling.

What is oil filter? What is its function?

Oil filter is a type of strainer using cloth, paper, felt, wire screen or similar elements. Oil filter removes the dirty elements of the oil in an effective way.

Ans)

What are the common troubles in lubrication system?

Troubles in Lubrication System:

There are a few common troubles in lubrication system such as: (1) Excessive oil consumption (2) Low oil pressure and (3) Excessive oil pressure. Ans)

Describe the pressure cooling system used in automobiles.

Pressure Cooling System:

It is the modification of ordinary water cooling system. In this system a pressure type radiator cap is used with forced circulation cooling system. It

Ans)

The cap is fitted on the radiator neck with an air tight seal. The pressure-release valve is set to open at a pressure between 4 and 13 psi. With this increase in pressure, the boiling temperature of water increases to 243°F (at 4 psi boiling temp 225°F and 13 psi boiling temperature 243°F). Any increase in pressure is released by the pressure release valve to the atmosphere. On cooling, the vapours will condense and a partial vacuum will be created which will result in the collapse of the hoses and tubes. To overcome this problem the pressure release valve is associated with a vacuum valve which opens the radiator to

FUEL & IGNITION SYSTEM

Explain air fuel ratio and its importance.

Ans) The air fuel ratio (AFR) defines the ratio of the amount of air consumed by the engine compared to the amount of fuel.

What are the functions of ignition system?

The functions of the coil ignition systems may be divided into three areas. These are:

Ans)

- ❖ Production of the high voltage necessary to produce a spark at the plug gap.
- ❖ Distribute the spark to all the cylinders at proper time based on the firing order.
- ❖ Varying the timing of the spark depending on the various operating conditions of the engine

Define carburetion.

Ans) The process of formation of a combustible fuel-air mixture by mixing the proper amount of fuel with air before admission to engine cylinder is called carburetion

What is a carburetor?

Ans) The device which does the process of formation of a combustible fuel-air mixture by mixing the proper amount of fuel with air is called a carburetor.

What is the function of spark plug?

A spark plug is used in SI engines to ignite the charge of air and fuel before the end of compression inside the engine cylinder.

Ans)

Spark plugs are specified by size, either thread or nut, sealing type (taper or crush washer), and spark gap.

How the spark plugs are specified?

Ans)

Name the types of ignition system used in I.C engines.

Ans) The two types of ignition systems used in I.C engines are Battery ignition system and Magneto-ignition system.

Define hot and cold plug.

Ans) A spark plug is said to be "hot" if it is a better heat insulator, keeping more heat in the tip of the spark plug.

A spark plug is said to be "cold" if it can conduct more heat out of the spark plug tip and lower the tip's temperature.

What is the use of fuel feed pump?

Ans) The function of feed pump is to deliver the fuel from the fuel tank to fuel injection pump through the fuel filter. The feed pump is attached to the injection pump.

What is an fuel injector?

Ans) A fuel injector atomizes the fuel through a small nozzle under high pressure and delivers into the engine cylinder for combustion.

What is detonation? Why it occurs?

Ans) Detonation or Knocking in spark-ignition internal combustion engines occurs when combustion of the air/fuel mixture in the cylinder does not start off correctly in response to ignition by the spark plug.

Under normal conditions the air fuel mixture ignites properly inside the cylinder during combustion. Detonation occurs when fuel pre-ignites before the reach of piston during ignition. It leads to a powerful explosion inside the cylinder and may divert the direction of piston. It has a sign to damage the piston components.

What is ignition timing?

Ans) It is the correct instant for the introduction of spark near the end of compression stroke in the cycle.

What is firing order? Mention the firing order for 4-cylinder inline engine.

Ans) The order or sequence in which the firing takes place, in different cylinders of a multi cylinder engine is called Firing order.

The firing order for a four cylinder inline engine is 1-3-4-2 or 1-2-4-3.

Define octane number and cetane number.

Ans) **Octane number** is the measure of the resistance of gasoline against detonation or preignition of the fuel in the engine. It is the measure of ignition quality of gasoline/petrol.

Cetane number is the measure of combustion quality of diesel oil or it is the measure of the ignition delay. It is the measure of ignition quality of diesel.

Explain the construction and working of ignition coil.

Ans) The construction of ignition coil is shown in figure. This coil contains a rod shaped, laminated soft iron core at its centre, and the soft iron cover surrounds both primary and secondary windings.

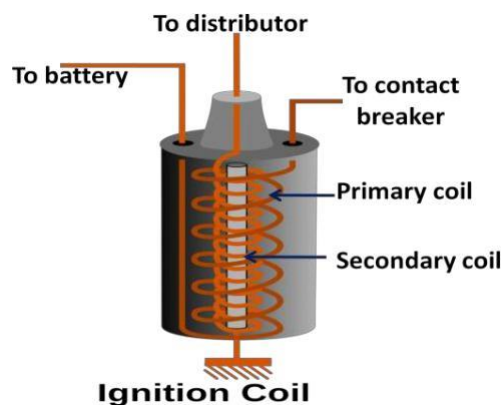

Ignition coil is the source of the high voltage pulses of current in the ignition system. The coil stores the energy in the magnetic field around the primary winding and at the required instant of ignition, transforms it into a pulse of high voltage current in the secondary winding. From here it is delivered to the correct spark plug via the high tension (HT) cables and distributor.

With a neat sketch explain the working of spark plug.

Ans) Construction and Working of Spark plug:

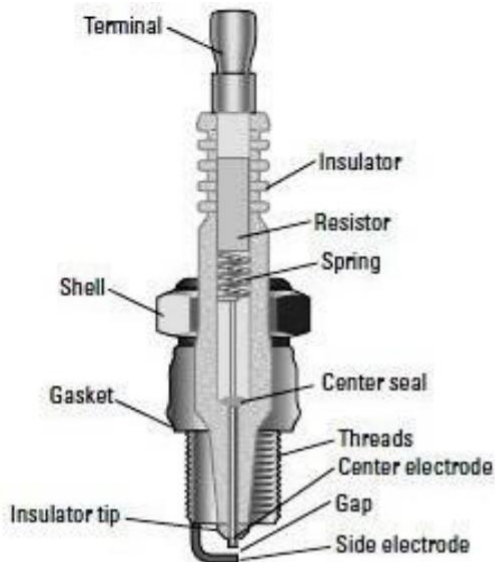

Anatomy of a spark plug.

A typical spark plug used in case of petrol engines. It is shown in the figure. It mainly consists of a central electrode and ground electrode. Central electrode is covered by means of porcelain insulating material. Through the metal screw the spark plug is fitted in the cylinder head plug.

Working:

When the high tension voltage of the order of 30000 volts is applied across the spark electrodes, current jumps from one electrode to another and produces a spark. This spark ignites the air fuel mixture inside the engine cylinder.

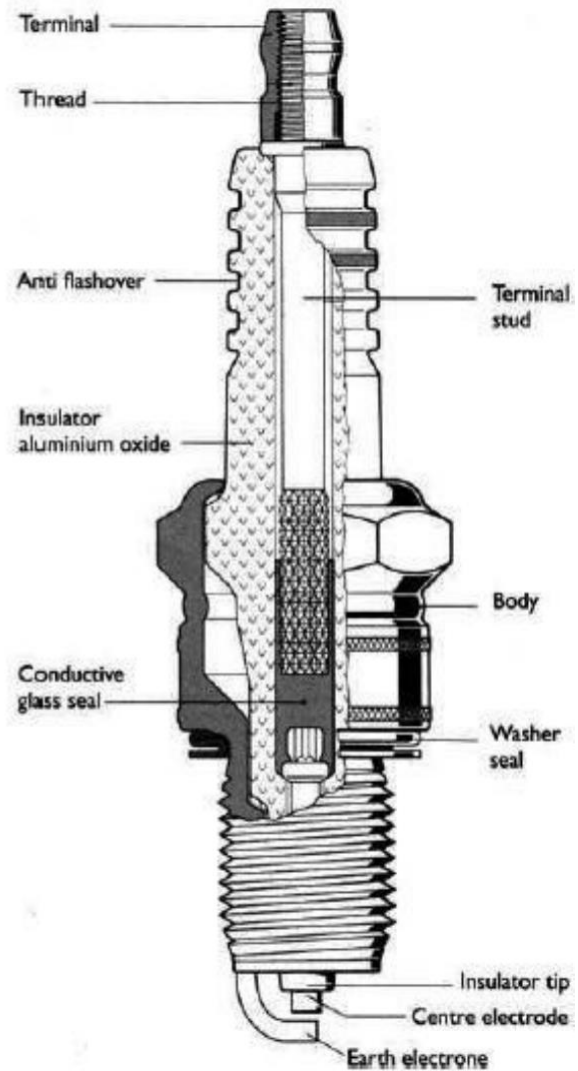

Explain battery ignition system with its line diagram.

Ans) Battery Ignition System:

The line diagram of battery ignition system for a 4-cylinder petrol engine is shown in figure. It mainly consists of a 6 or 12 volt battery, ammeter, ignition switch, auto-transformer (step up transformer), contact breaker, capacitor, distributor rotor, distributor contact points, spark plugs, etc.

In this system there are 4-spark plugs and contact breaker cam has 4-corners. The ignition system is divided into 2-circuits:

- 1) **Primary Circuit:** It consists of 6 or 12 V battery, ammeter, ignition switch, primary winding it has 200-300 turns of 20 SWG (Sharps Wire Gauge) gauge wire, contact breaker, capacitor.
- 2) **Secondary Circuit:** It consists of secondary winding. Secondary Ignition Systems winding consists of about 21000 turns of 40 (S WG) gauge wire. Bottom end of which is connected to bottom end of primary and top end of secondary winding is connected to centre of distributor rotor. Distributor rotors rotate and make contacts with contact points and are connected to spark plugs which are fitted in cylinder heads (engine earth).

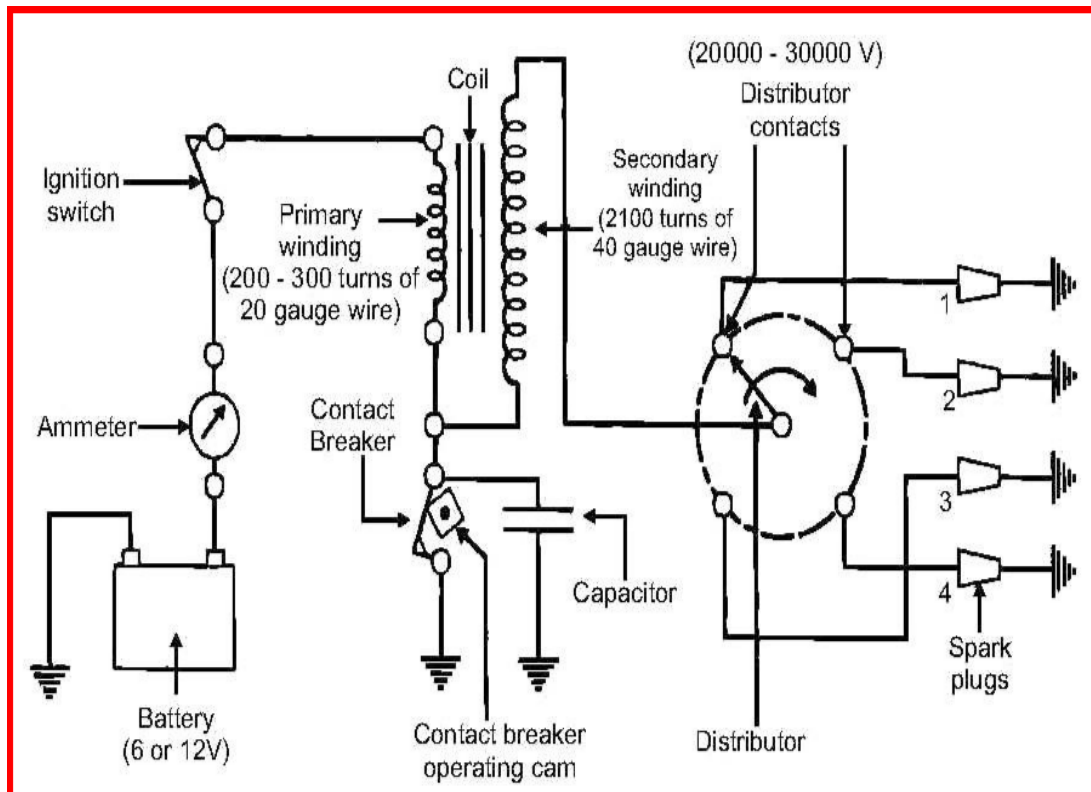

BATTERY IGNITION SYSTEM

Working :

When the ignition switch is closed and engine is cranked, as soon as the contact breaker closes, a low voltage current will flow through the primary winding. It is also to be noted that the contact breaker cam opens and closes the circuit 4-times (for 4 cylinders) in one revolution. When the contact breaker opens the contact, the magnetic field begins to collapse. Because of this collapsing magnetic field, current will be induced in the secondary winding. And because of more turns of secondary, voltage goes up to 28000-30000 volts.

This high voltage current is brought to the center of the distributor rotor. The distributor rotor rotates and supplies this high voltage current to the proper spark plug depending upon the engine firing order. When the high voltage current jumps the spark plug gap, it produces the spark and the charge is ignited-combustion starts-products of combustion expand and produce power.

Explain Magneto ignition system with its line diagram.

Ans) Magneto Ignition System:

In magneto ignition system a magneto is used to generate electric current for producing spark. Main components of magneto ignition system are: frame, permanent magnet, armature, soft iron field, rotor, primary and secondary winding, contact breaker and condenser.

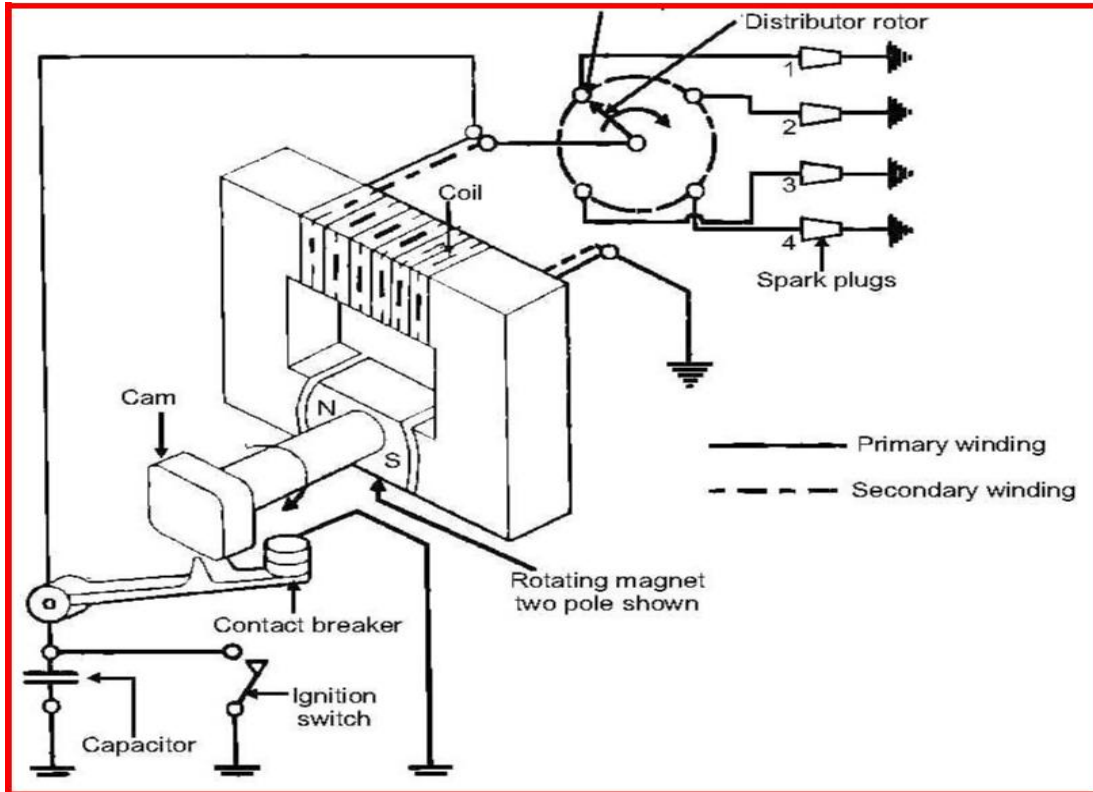

MAGNETO IGNITION SYSTEM

The armature is driven by the engine. When the armature rotates, current flows in the primary winding. This current flows into the condenser by a contact breaker. Condenser sends back high voltage high current into the secondary winding. Current is then flows into the distributor. Distributor distributes the current into the spark plugs.

Explain the working of simple carburetor.

Ans) The simple carburetor mainly consists of a float chamber, fuel discharge nozzle, a metering orifice, a venturi, a throttle valve and a choke. The float and a needle valve system maintain a constant level of gasoline in the float chamber.

If the amount of fuel in the float chamber falls below the designed level, the float goes down, thereby opening the fuel supply valve and admitting fuel.

When the designed level has been reached, the float closes the fuel supply valve thus stopping additional fuel flow from the supply system.

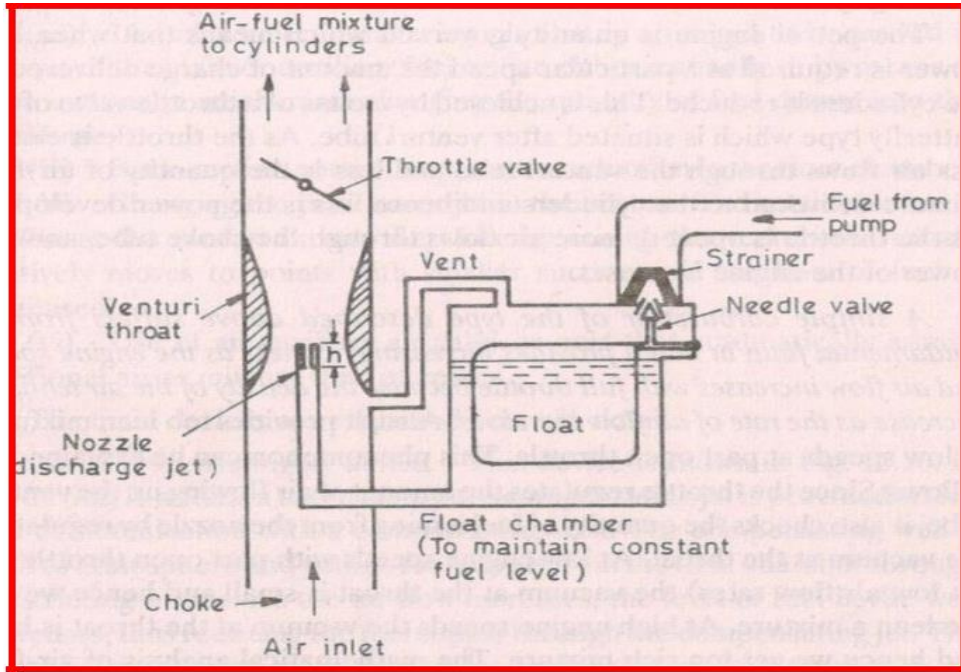

Solex carburettor:

- provide ease of starting, good performance, and reliability -used in Fiat and standard cars and Willey jeep -
- Bi-starter is used for cold starting
- well of emulsion system is used for idling and slow running condition -
- diaphragm type acceleration pump is used for increasing speed case

Explain the multipoint fuel injection system.

Ans) Fuel injection is a system for mixing fuel with air in an internal combustion engine. Fuel injection atomizes the fuel by forcibly pumping it through a small nozzle under high pressure. The construction of multipoint fuel injection system is shown in figure.

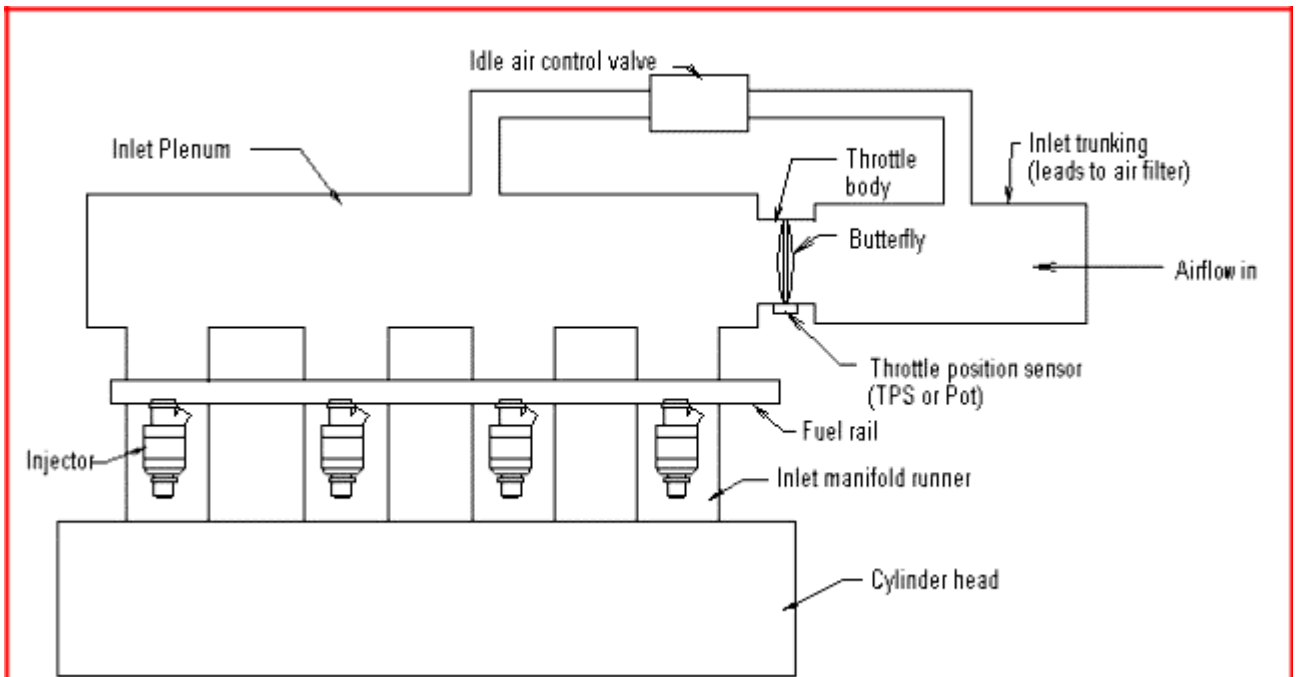

Multi-point fuel injection (MPFI) injects fuel into the intake port just upstream of the cylinder's intake valve, rather than at a central point within an intake manifold. In MPFI

systems fuel is injected to the cylinders in groups in which fuel is injected at the same time to all the cylinders

Describe the working principle of an fuel injector with help of a neat sketch.

Ans) The fuel injector is used to spray fuel into the engine cylinder. It is fixed to the cylinder head. Fuel injector atomizes the fuel by forcibly pumping it through a small nozzle under high pressure.

A mechanical type fuel injector is spring-loaded into the closed position and is opened by fuel pressure. Its construction is shown in figure.

The fuel is fired into either the inlet manifold or the inlet port via an injector. Fuel from the tank is pumped at high pressure to a fuel accumulator. From there it passes into the fuel distributor, which sends fuel to injector, from where it is fired into the inlet port.

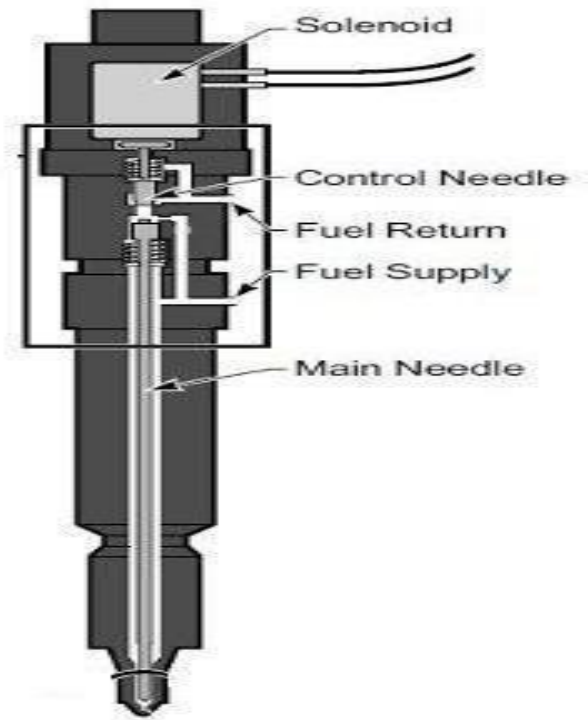

State the difference between the Battery and Magneto ignition system.

Ans) Difference between Battery and Magneto ignition system:

Battery Ignition System

1. Battery is necessary.
2. Battery supplies current in primary circuit.
3. A good spark is available at low speed also.
4. Occupies more space.
5. Battery recharge is necessary.
6. Mostly used in case of cars and buses.
7. Battery maintenance is required.
8. It is commonly used because of its combined cheapness, convenience of maintenance, attention and general suitability.

Magneto Ignition System

1. No battery is necessary.
2. Magneto produces the required current for primary circuit.
3. During starting the quality of spark is poor due to low speed.
4. It is more compact.
5. Not required because there is no such arrangements.
6. Mostly used in motor cycles and scooters.
7. No such arrangement is there.
8. It is an efficient, reliable, self contained unit, which is often preferred for air craft engines because storage batteries are heavy and troublesome.